

Who Knows Your HIV Status II?: Information Propagation Within Social Networks of Seropositive People

Gene A. Shelley, D. Killworth, H. Russell Bernard, Chris McCarty,
Eugene C. Johnsen, and Ronald E. Rice

We seek to explain on what basis people choose to tell stigmatizing information about themselves to others. In particular, are there any rules governing how such decisions are made? We asked 70 HIV-positive individuals whether they knew various items of knowledge about their network members, and vice versa. These items range from things which might be known easily (e.g., marital status), things which are more difficult to know (e.g., blood type), to potentially stigmatizing information such as criminal record and HIV status. The information that one person knows about another may predict whether the latter's HIV status is also known. We examine this question using a combination of ethnography and decision trees. Even an apparently simple decision – whether or not to tell someone that you are seropositive – turns out to be complicated; yet the complexity can be extracted from open-ended interviews.

Key words: HIV/AIDS disclosure, decision modeling, ethnography, people with HIV/AIDS

Introduction

This study is concerned with a person's decision to pass on a piece of personal information that is highly self-regulated because it could be particularly stigmatizing: being HIV-positive. How decisions like this are made is not well understood, and has important ramifications for the individuals involved, and, in the wider context, for the provision of and access to health care and other resources. The stigma related to disclosure of HIV status can be particularly devastating because many of the modes of transmission

of HIV (illicit sex or drugs) can be also stigmatizing, thus resulting in individuals feeling highly or "super" stigmatized (Greene et al. 2003; Herdt 2001; Lee, Kochman, and Sikkema 2002). Cultural factors also affect the amount of stigma an individual feels and the realities of living with HIV. This illustrates the importance of ethnographic research with HIV populations (Herdt 2001; Lee, Kochman, and Sikkema 2002; Parker and Ehrhardt 2001).

The threat of stigma inhibits interpersonal communication. Yet it is just this communication that informs people about one another and on which relations are formed, maintained and destroyed. Berger and Calabrese (1975) argue that people develop relationships by reducing uncertainty through communication with each other. Getting to know someone well requires many interactions over time and intimate relationships require reducing uncertainty through shared experience and communication (Berger and Calabrese 1975). Over time, people disclose information about themselves to others as they develop personal relationships.

Although disclosing one's HIV status can result in negative outcomes, some researchers (Latkin et al. 2001; Pequegnat et al. 2001; Simoni et al. 2000) find that disclosure can result in increased social and emotional support. For example, Sherman et al. (2000) show that disclosure of HIV information by children to their networks has a measurable improvement on their psychological health as well as on their CD4 cell counts.

Thus "people must balance competing needs to obtain benefits from disclosure yet avoid negative consequences

Gene Shelley is an Adjunct Professor at Georgia State University, Atlanta, GA, USA, now a Behavioral Scientist in the Division of HIV/AIDS Prevention, National Center for HIV, STD and TB Prevention, Centers for Disease Control and Prevention. Peter Killworth is an Individual Merit Scientist and Professor at the National Oceanography Centre, Southampton, UK. H. Russell Bernard is Professor of Anthropology at the University of Florida, Gainesville, FL, USA. Chris McCarty is Survey Director for the Bureau of Economic and Business Research at the University of Florida, Gainesville, FL, USA. Eugene Johnsen is Emeritus Professor of Mathematics at the University of California, Santa Barbara, CA, USA. Ronald Rice is the Arthur N. Rupe Professor in the Social Effects of Mass Communication, Dept. of Communication, University of California, Santa Barbara, CA, USA. This work was conducted under NSF grant no. SBR-9213615. Georgia State University provided office space for some of the interviews. We thank Howard Kress and Craig Lindsey for assisting with some of the data collection. Most of all, we are extremely grateful for the time, energy and openness of all the HIV-positive individuals who participated in these interviews.

from sharing” (Greene 2000:123). They must, in other words, assess how different people (a mother, an employer) will respond, whether the potential benefits outweigh the possible negative consequences, whether there is likely to be increased social support, and so on. The tendency of a person to disclose his/her positive HIV status decreases along a continuum from spouses and nonmarital sexual partners, to friends (especially high if both discloser and target are gay), to nuclear family (the probability is higher for disclosing to siblings than to parents; lower for brothers than for sisters; lower for fathers than for mothers), to extended family, to community, and to acquaintances. People are more selective about disclosing they have HIV/AIDs than other illnesses; gay men with many sexual partners are particularly selective about whom they tell (Greene 2000).

Derlega et al. (2004) showed that the primary reasons for HIV-positive men and women to disclose their status to friends, intimate partners, and casual partners were catharsis, duty to inform others, desire to educate, and having a close/supportive relationship. Less strong reasons were similarity with the target, and to test the other’s reactions. Reasons for non-disclosure included privacy, self-blame, fear of rejection, and protecting the other. Some of these reasons interacted with both gender, and type of relationship.

Greene and Faulkner (2002) found that adolescents’ decisions to disclose a positive HIV diagnosis were influenced both by expected response, and by features of the target of disclosure. Their expectations and actual responses included negative emotional reactions, support, treating them differently, being treated no differently, telling others, and unsure. Serovich et al. (1998) coded reactions to disclosures of HIV-positive status to family members into six primary categories (including 31 subtypes): intellectual (such as information gathering), physical (hugs), spiritual (prayer), relational (question), instrumental (offer help), or emotional (anger).

In our research, we treat the act of disclosure as an information flow problem within a social network, the first step in the diffusion of this information into a larger group. Simply counting the numbers of people in social networks (cf. Freeman and Thompson 1989; Killworth et al. 1990), or studying the characteristics of network members (e.g., Bernard et al. 1982), cannot be sufficient to describe how people come to know aspects of their network members. Studying *in situ* information flow is difficult, however. Experiments out of the laboratory that mimic the complexities of real-world information flow are hard to monitor (see Serovich et al. 1998; Shelley et al. 1990 for two examples), so we are confined to judging that flow after the fact.

This differs from the traditional diffusion of innovations approach, where information about some topic external to the people concerned (the innovation), rather than personal disclosure, is the primary topic. For example, Rogers (2000) and Dearing, Meyer and Rogers (1994) examined the spread of HIV treatment methods in various cultures, and Backer and Rogers (1998) studied adoption of AIDS programs in the workplace from a similar perspective. Whether health

campaigns are effective is also a key object of study, e.g., Rice and Atkin (2001), Rogers (1996). However, some diffusion studies have looked at disclosure about health matters, such as communication between a professional and a patient, e.g., Bensing (2000), or between individuals as well as with professionals (Elford et al. 2000).

Another tradition of research on decisions involves building decision models. H. Gladwin (1971), Quinn (1978), and Plattner (1982) used ethnographic decision models to understand the price that people place on products. C. Gladwin (1976, 1980) modeled how farmers decide on allocating resources (land and inputs) to various crops; Ryan and Bernard (2006) modeled the decision to recycle aluminum beverage cans; Gatewood (1983) modeled the decision by fishermen on where to hunt for prey; and medical anthropologists have modeled treatment decisions (Hill 1998; Mathews and Hill 1990; Ryan and Martinez 1996; Weller, Ruebush and Klein 1997; Young 1980; Young and Garro 1994). In all these cases, decision modeling was the object of the research and data were collected systematically to derive and test a model of a particular behavior.

Omarzu (2000) has proposed a disclosure decision model wherein situational cues and individual differences affect an individual’s possible goals (of approval, intimacy, relief, identity and control). Her model first asks whether a particular goal is salient (if not, no disclosure occurs). Otherwise, disclosure depends on whether there is an appropriate target to disclose to, and if disclosure is an appropriate strategy (a question which will be relevant in our work, and which remains hard to measure). Only if the answers to both questions are affirmative does the model continue to question subjective utility and risk.

In this paper we address similar issues about stigmatizing information flow but from a different direction. We ask: can we delineate rules of how HIV-positive people choose to tell others about their HIV status? We derive and test these rules from demographic and ethnographic data collected from HIV-positive people who came in to a clinic (Shelley et al. 1995). The data were part of a larger study on the development of methods to count ‘hard to count’ populations (Killworth et al. 1998).

In the next section of the paper we discuss the data sources, and then examine to whom informants tell their HIV status. To explain this, we need to understand the more general question of what types of information people know about each other. Then we examine the ethnographic evidence as to how informants made the decision to disclose, or not disclose, their status, and we formulate approximate rules for the process. The final section puts these rules onto a firmer footing, testing several methods in an attempt to model this process.

Data Sources

A clinic-based convenience sample of 70 HIV-positive informants provided data about themselves, including race, gender, income, education, how long they had been

HIV-positive, their sexual orientation, etc. In open-ended interviews, informants were also asked, among other things: (1) how their family and friends reacted when they learned that the informant was HIV-positive; (2) whether they generally chose to limit knowledge of their HIV status; and (3) what influenced them in deciding who to tell about their HIV status. The data, comprising lengthy narratives, are fully described in Shelley et al. (1995).

For each informant, we constructed a list of social network members using five network generators—devices that cue the names of people in a person's social network (henceforth “network alters”, or simply alters). The generators involved showing informants: 1) a list of 40 popular first names (an extension of the list in McCarty et al. 2001); 2) a list of 50 occupations representing high, middle and low status (Shelley et al. 1995); and asking informants to list 3) the people they “talked with about important, confidential matters” (Burt 1984); 4) the people “who are important to you” (Myers 1981); and 5) people who helped them when they needed various things (Fischer 1982).

Next we asked informants a series of questions about each of the alters they had named: the type of relationship (friend, relative, co-worker, etc.), the alter's gender and race, if the alter lived in the same area, the *length of time* informants had known the alter, and *how frequently* the informant was in contact with the alter. Informants judged *how close* they felt to each alter, *how well* they knew each alter, whether each alter was *supportive*, neutral or unsupportive, and how *influential* each alter was in the informant's life. (We use these italicized variables below.)

Finally, we showed informants a list of 30 things that people can know about one another—things like age, occupation, number of siblings, blood type, HIV status, and so on¹. We asked informants if they knew each of those things about each alter and whether each alter knew each of those things about them. Note, however, three caveats:

1. We did not contact the alters of the informants and can not confirm what informants said that alters knew about them. Projections of what other people know is subject to obvious bias and internal cognitive readjustments (see Rice and Aydin 1991, Rice 1993). In what follows, we talk about “alters ‘knowing’” things about the informants, rather than the clumsier, but more accurate, “informants reported alters knowing.”
2. Informants told us that something *was known*, but not when or how the information was acquired. We do not know, then, the *order* in which information was acquired by the alter or informant.
3. The data were not collected with the present study in mind, so some analyses cannot be made.

To What Kinds of Others Do Informants Disclose Their HIV Status?

The first question to answer is simply: to what kind of people (alters) do those with HIV disclose their status? In the sections that follow, we describe the distribution, across alter

types, of knowledge about informants. We use this as a proxy for whether the informant has disclosed that knowledge to an alter, and we develop decision trees about which of these information items, along with other demographic attributes, influence informants to disclose or not disclose their HIV status to various alters.

We asked informants which categories of others they would tell and which they would not tell about their being HIV-positive. The categories of relationship are listed in Table 1, and informants were able to list more than one category of person. Informants generally reported that they would tell family, very close friends and sexual partners, but even in these cases, divulging the fact that they were HIV-positive was on a need-to-know basis: before a new sexual encounter or if the other person is perceived to be at risk from contact with infected blood (e.g., medical or law enforcement personnel). In many cases, family would not be told until the informant's health started deteriorating.

One black woman said: “Yes, because I'm healthy I feel like they don't need to know unless I'm ill. I don't want them to feel sorry for me and worry about me.”

A gay, white man said: “I haven't let my family know. Last year I told them I was gay. My sister asked me about being HIV-positive and so I told just her. I don't think it's necessary to tell now. Not until I become ill.”

Another white man said: “If they ask I will tell but I don't feel it is now for them to know. I don't want them to say ‘poor him’. I want to live as normal a life as possible as long as possible. If I get more ill I may talk about it more.”

And another black male informant commented: “I feel I'm not ready to tell but I need to tell them before I get ill. I told one sister (that I was HIV-positive). At a family reunion two weeks ago, another sister popped up and asked point blank if I had AIDS—I said ‘No’.”

HIV-positive status might also be revealed if the informant judged that the person would be able to provide present or future emotional support. One informant said: “Yes, I would tell family, friends or (people in) community based organizations because they would give me support.” By contrast, informants reported overwhelmingly that they would *not* tell employers or co-workers, for fear of rejection. They also would not tell some or all family members because of this fear, nor tell people they just met.

How Much Information Is (Perceived To Be) Known by Alters?

To explain knowledge by one person about another, we define two units of analysis involving the 30 items of knowledge in note 1: what the *informant knows* about an alter (‘ik’), and what an *alter ‘knows’* (remember, this is really what the informant perceives the alter knows) about the informant (henceforth ‘ak’). Each item is binary (yes/no). Both data sources—ak and ik—have potential errors. Despite these potential sources of error, Shelley et al. (1995) found a 0.97 correlation between ak and ik. We believe that the former

Table 1. Alters Who Would Or Would Not Be Told About Informant's HIV Status

Would be told (% cases)	Would not be told (% cases)
Sex partners (72)	People at work (58)
Family (52)	Family (32)
Medical personnel (35)	Strangers (23)
Really close friends (19)	New people (9)
Similar to informant (13)	Boyfriend/girlfriend (6)
Friends (7)	Friends (6)
Children (3)	Children (6)
Accepters of HIV (3)	People who can't keep a secret (4)
Potential sex partner (1)	Neighbors (3)
Loved ones (1)	People at church (3)
Roommate (1)	People in authority (3)
Clergy (1)	Need to know only (3)
People at risk (1)	Would not tell anyone (3)
Law enforcement personnel (1)	Non-sex partners (1)
Employers (1)	People not seen often (1)
Schoolmate (1)	People who like me (1)
	Homophobics (1)
	"Black folks" (1)

errors are less likely to occur. Informants know when they have passed information directly to an alter, though they could be unaware that the information was acquired by an alter through a third party.

Thus our analyses here are based only on the ak data.

Figure 1 shows a histogram of the distribution of the number of items known by alters. There is a (broad) peak at six items known, with a rough decrease on either side (knowledge of zero items is unusual, of course) but the number of alters reported knowing above 23 items increases as the number of items increases, only dropping at 30 itself. Thus alters tend to know either approximately six items, or they know a great deal of information, about an informant. This mirrors what informants told us about their ak patterns: some report that most of their alters know a great deal about them, some report that most alters know little about them, and some report a wide variation in knowledge across their alters.

Knowledge of items, predictably, differs strongly depending on the type of relationship between informant and alter (we used a list of 26 possible relationships; McCarty et al. 2001). Indeed, the amount of alters' knowledge about the informant (the 'ak' items) varies from a maximum mean of 25.5 items known by 'parents' to a minimum mean of 2.33 known by the category 'patients of the informant'. Particularly striking is the difference between 'acquaintances' (who know 6.1 items) and 'friends' (who know 12.3 items, $p < 0.001$). Surprisingly, friends are reported to outnumber acquaintances by 714 to 220. This may reflect the ethnographic finding by Shelley et al. (1995), that people living with HIV and AIDS reduce contact with their acquaintances to avoid dealing with the problem of telling those people about being HIV-positive. As one typical informant said: "I shunned away from some. It's not only that they stay away from you. You

lose them on your own because you don't call them or visit them anymore."

This finding was confirmed in the analysis by Johnsen et al. (1995) and the fact that knowledge about personal information is withheld by those who limit their networks is confirmed here: the mean number of items known by alters in networks of those who said they limited knowledge is 11.7, compared with 15.4 for networks of those who do not limit ($p < 0.01$).

Figure 1. The Percentage of Alters Knowing 0, 1, ..., 30 Items about Informants

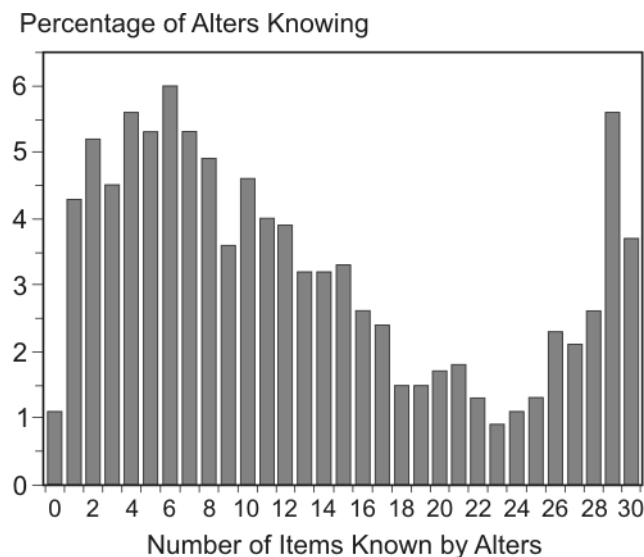

Perhaps being in a larger network encourages greater information propagation. In fact, except for blood type, the correlations *between* the number of alters who knew a piece of information about the informant, and the informant's network size, were all positive and significant. For example, the correlation for HIV status (ak22 in note 1) and network size is 0.63. This correlation could, however, be an artifact of simply being exposed to more alters, so we correlated network size with the *proportion* of alters knowing an item. These correlations were uniformly not significant (that for HIV status was -0.11, for example), with wide variations of the proportions known across informants. Thus: *informants with large networks do not have any different proportion of alters who know any particular item, than do those with small networks.*

Ethnographic Clues for Decision Tree Construction

From close inspection of informants' narratives about their decision to reveal their HIV status, we developed the following 11 rules (in no particular order):

1. Does this alter already know my sexual orientation (e.g., that I am gay)?

It may be more difficult to tell someone two pieces of potentially shocking information at one time. Finding out someone (e.g., your son) is both gay and HIV-positive is perhaps too much to deal with at once. One bisexual informant said, "My family doesn't know I have had homosexual experiences. My father is a minister and that would not go over well." A gay male informant said, "No one in my family knows. I will probably tell my little brother. I think they (my family) will disown me. They don't know I'm gay either. I am worried to death. I have told very few people."

2. Do I limit who knows about my HIV status?

If a person limits knowledge generally (a question we asked), then it would be harder for that person to tell about anything personal, let alone HIV status. One informant said, "Yes, I have limited the people who know, especially my father's family. I listen to them talk and I can hear some of the negative things they say so I think it's best I don't tell them. Most of my friends know except for a couple of them."

3. Is this alter prejudiced against gays or lesbians?

If an alter is thought to be prejudiced against gays and lesbians, then an informant is less likely to reveal his or her HIV-positive status, even if the informant involved is not gay or lesbian. One informant said he wouldn't tell "because of discrimination in employment and socially too. There is prejudice." On the stigma of being labeled homosexual, one informant said:

"People treat you differently in a homophobic type sense. You are branded, you are gay and you may have HIV."

Another said:

"People don't want to know their HIV status. They are in denial. They may not go to support meetings because they feel they are labeling themselves. They feel like the bottom of society."

4. Is this alter perceived as supportive of me?

Alters are more likely to find out information about informants if the reaction of the alters to the news will be positive. Perhaps the alter shares similar experiences (e.g., is also gay, or is also HIV-positive). As one informant said:

"My friends have it themselves so they understand. They said, 'why are you hanging out with us? You know we got that thing.'" Then I told them I had it too." Another said: "Yes, I would tell my roommate, family, closest friends, because I wanted support. They reacted very favorable and very, very supportive." And another said: "Yes, I would tell care givers or friends that I want to be my care givers, peers in support groups. If I need to tell them to help myself or anyone that needs to know."

5. Is this alter educated about HIV transmission?

If alters give evidence that they do not know how HIV can be transmitted, those alters may be fearful of sharing utensils or personal items with the informant, or even avoid any contact at all. Many informants talked about their alters being "backward", "ignorant" or "uneducated" about how HIV can be transmitted. Several informants spoke about this. One said:

"Yes, I feel it is my personal right to tell who I want to tell. It is an individual thing. If I'm not putting their life in jeopardy there is no reason to tell them. Ignorant people think you can get it from talking to you." Another said: "My family doesn't know. Two friends, I've told, I have never heard from them again. Some friends not HIV-positive and not gay have been very supportive. You can sort of tell who the intelligent people are. I discriminate who I told." And finally: "If they don't have knowledge they are scared. They are acting ignorant. I'm keeping to myself day by day."

6. Does this alter live in the same area as me? (Do I have opportunities for contact?)

Informants often said they wanted to reveal their HIV-positive status in person. They said things like:

"I would not tell my mother or grandmother. My grandmother is 74 years old. I don't think they can deal with my being HIV after hearing about my being paralyzed. It's just too many things to try and dump on them. I have to tell them face to face someday." Another said: "I will eventually tell my children, my wife, my brothers and sisters ... feel that they aren't ready to know and I ain't ready to tell. They live in (name of town). It would really put them through a lot, especially my son. I haven't seen them in a while, it will be a year or more."

7. Will this cause the alter unbearable pain (shame or hurt)?

Informants were trying to be very careful about the feelings of their alters, especially their family members, because families can share in an individual's HIV stigma (Pequegnat et al. 2001). One informant said:

"I haven't told my mother. Why put her through that? She asked if I had it and I denied it to her. My father has been absolutely wonderful and supportive." Another said: "I wouldn't tell aunts and uncles because I don't live up there. My mother would have to deal with it." And another said: "When I first found out I didn't tell anyone. My duty was to my mother and father who would be hurt by this and ashamed. But now my parents know and they are very supportive, probably the exception to the rule."

8. *How close do I feel to this alter?*

How close people feel to one another has a lot to do with what they talk about and reveal to each other. Feeling close to someone means that the alter is more likely to know sensitive or stigmatizing information. On the importance of closeness, one informant said:

"I would tell closest friends... because they are close to me and help me through my crises." Another said: "Yes, I told Mom, because we are very close. At the moment I don't think there are others I would tell."

9. *Do I trust this alter not to tell others information that I don't want generally known?*

Information that one wants to keep private is not likely to be revealed to someone who can't keep secrets. On the importance of trust and keeping confidences, one informant said:

"I would not tell somebody I didn't trust. I'm learning to take risks and trust people. I would not volunteer information about my HIV status to a potential employer." Another said: "Some of my friends don't know. I can't tell everybody because some people can't keep in confidential information."

10. *Am I or my network alter African American?*

Being gay is very stigmatizing in the African American community, for both men (McLean 2003; Fullilove and Fullilove 1999) and women (Mays et al. 2003). Here is how one gay black man responded to the question of who he would not tell about his HIV status:

"Black folks. I will not tell any black people or close friends unless they open up to me first and we care about each other. I would not tell a potential employer. Employers do not want to hire us (HIV-positive people)." A non-gay black man said: "If I had sexual relations with a girl I would tell but I'm real macho so it can't come out easily because being HIV is connected by blacks with being gay." A non-gay black woman said: "We take care of ourselves and are very independent. (We are) most likely not to tell HIV status. You feel like you can take care of it. If you tell someone you are asking for help."

11. *How long have I known about my HIV-positive status?*

The longer someone has known that he or she is HIV-positive status, the more likely it is that information is known to others (this will be illustrated in Figure 2).

In addition, we include below three additional features which, while not identifiable within the ethnography, are likely to have an impact on the decision process: how well an alter is known, frequency of contact with alter, and whether the alter is talked to about important matters.

Accounting for Decisions to Reveal HIV Status to Categories of Alters

In this section, we attempt to explain how informants make the decision to reveal, or not reveal, their HIV status to others, based on the above 11 decision rules. However, these rules are insufficient to account for information flow. Geographical and social barriers, for example, limit the transmission of some information (Killworth et al. 1998; McCarty et al. 2001). Thus, the rules we present work both alone and with structural and demographic factors to determine an individual result: whether a particular alter is perceived to know about a particular informant's HIV status. The following factors are available in our data as components for decision tree modeling: sexual orientation of the informant (ak27 in note 1), whether the informant limited knowledge of her or his condition, how well known the alter is, whether the alter provides support, if the alter lives in the same area, the frequency of contact with the alter, how emotionally close the alter is, whether the alter was talked to about important matters, and the race of the informant and the alter. We do not have quantitative data on Rule 3, above (prejudice against gays), on Rule 5 (alter education about HIV transmission) or on Rule 7 (pain or shame to alters). If we had quantitative data on Rules 3, 5 and 7, the decision trees we present next might have been improved. Similarly, while we might impute answers to Rules 9 (trusting alter) and 11 (how long HIV status is known), the accuracy of the imputation is suspect and so these are also unused.

We begin with a straightforward statistical approach, seeking logit fits to the decision to reveal status using informant and alter information, guided in our choice of predictor variables by the ethnography. These approaches explain dependencies, but do not show how decisions may actually be made. The main body of this section discusses the construction of decision trees, which model the actual decision process.

Correlational Approaches

How informants decide whether to tell their HIV status to their alters is fairly complicated, and so not described particularly well by simple correlations. The largest single raw (i.e., non-logit) correlation between HIV status (ak22 in note 1) and any informant or alter data was with how 'close'

the informant felt to the alter, accounting for nine percent of the variance.

The next phase of the analysis involved discriminant analyses of knowledge of HIV status, again using all the variables in note 1 as potential predictors. General health status (ak23 in note 1) proved dominant in predicting HIV status. If the ak variables in note 1 were excluded from the analysis, then *know well* and/or *close* became again the main predictive variables; if these in turn are removed, they are replaced by *how influential* the alter is said to be and the *length of relationship* with the alter.

The percentage of alters knowing an informant's HIV status increases dramatically $r = 0.83$ with the time since the informant's onset of HIV (Figure 2). However, the equivalent graph plotted against length of time of the relationship shows a peak at medium-length relationships. This is not usual: although the equivalent diagrams for items of knowledge other than HIV show some noise, almost invariably knowledge increases monotonically with length of relationship. This anomaly may result from a person deliberately reducing their network size or from reluctance by some HIV-positive participants to tell their families about their condition until it had progressed. In some cases, family members lived far away and participants were waiting until a visit home before breaking the news of having HIV—something that might not take place for years. Thus, some alters who have very long relationships with informants are unaware of those informants' HIV status.

In contrast, people whom an informant has known only briefly, such as medical staff whom they meet during the treatment process, are likely to know the informant's HIV status, while not knowing much else about the informant. Part of the decision may also involve chance events in idle conversation with an alter; the probability of such things occurring depends on the frequency and depth of contact between informant and alter. In addition, there may well be some ill-defined utility function which the informant uses to make the choice.

With this as background, we examined five multiple regressive logit fits to the key outcome variable, knowledge of HIV status (ak22), using a variety of potential explanatory data. The data for each of the logit regressions were:

1. informant and alter data from note 1, not including the ak data;
2. the other 29 ak data in note 1;
3. the variables in 1 and 2 above, combined;
4. the other ak data in note 1 but excluding ak23 (general health status); and
5. the variables in 1 and 2 above, combined, but excluding ak23 (general health status).

The fits all used a chi-square acceptance of five percent. All the data were entered in the analysis. The results were judged for acceptance by what percentage of the knowledge of HIV status were correctly classified by the logit fit (57 percent of the cases had HIV status known by the alter, for comparison). The fits model the probability that HIV status

Figure 2. The Percentage of Alters Knowing the Informant's HIV Status, as a Function of the Time Since Onset of the Disease

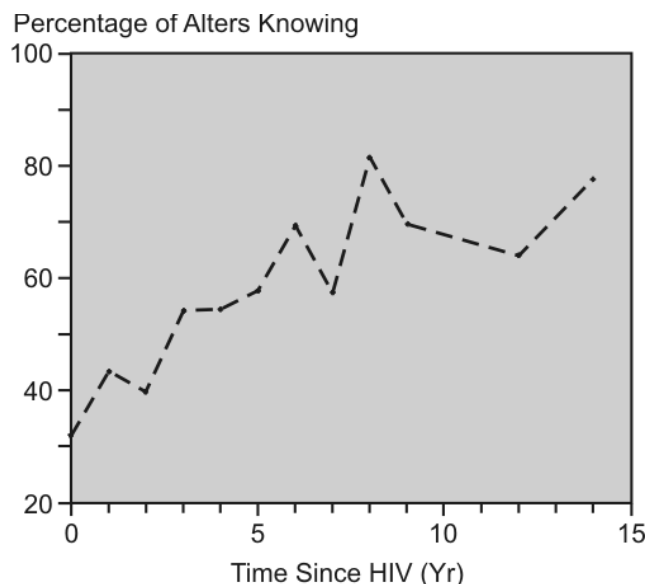

is not known, so negative coefficients mean that knowledge of HIV status increases as the data value increases.

The first logit fit, 1), examined how well simple knowledge of informant and alter attributes could account for knowledge of HIV status. 75 percent of the cases were correctly classified. Alters were more likely to know HIV status for white informants living in the same area as the alter, if the alter and informant are well related, if the alter is married or cohabiting, if the alter's sexual orientation is not 'straight', if the informant and alter have frequent contact, and if the alter is seen as supportive. These results were clearly successful (judged against the null hypothesis fit of guessing that HIV status is known, with 57 percent success rate), although the results are perhaps somewhat predictable.

The second fit, 2), used whether or not the alter knew other information about the informant to predict knowledge of HIV status. This yielded statistically significant dependencies on 17 of the other 29 items. While many of these imply a degree of intimate knowledge of the informant by the alter (e.g. ak17, whether the informant has ever been threatened by a gun), others (e.g. ak1, type of usual work of informant) are not, so that the 85 percent correctly classified data is excellent and contains non-intuitive findings.

Finally, case 3) combines the two fits but hardly improves on the predictability (87 percent). Interestingly, the roles of some of the ak data disappear when informant and alter data are included, but those that remain continue to have the same sign of dependency.

The success of such fits means that decision tree approaches are likely to be successful themselves, and their

structure may well indicate how the decision is actually made.

Logit fits omitting ak23 (general health status), but otherwise identical to 2) and 3) above, were also performed. We wished to ensure that the high degree of explanation of the data was not due to the tendency of knowledge of general health status to act as a proxy for knowledge of HIV status. The percentages predicted by the best fits dropped in 4) from 85 to 82 percent, and in 5) from 87 to 86 percent, showing that this factor does not play a major role.

Recall that all these fits were performed on the entire data set (no training on half the data and testing on the other half was included), so that in some sense these results are the 'best' obtainable but will contain some noisiness from the fit. The split-half results for the decision trees below would therefore appear poorer than those above.

Decision Trees: Predicting Knowledge of HIV Status across all Alters

We now present decision trees using various combinations of alter knowledge items and other variables to explain the decision whether to disclose HIV status. The accuracy of a tree is judged by its classification rate, as for the logit fits.

To construct a decision tree, we cannot go through a classical tree-making ethnographic procedure (Gladwin 1989), but instead use a method relevant to uncertain, noisy domains. Mingers (1989, 1990) has surveyed approaches for tree-making in such cases. In summary, we use a split-half approach with randomly re-ordered data, and use the first half to construct an initial tree accounting for this section of data. Such a tree is both noisy and—in many of its branches—lacking statistical validity. The second half of the data are used to prune the existing tree back to a size which has validity (using, in this case, the error-complexity method; Mingers 1990). As the tree is pruned, the accuracy of it tends to increase for a while, before reaching a maximum accuracy after which the accuracy decreases once again as pruning continues. Mingers (1990) discusses how to select a tree whose accuracy is within a standard error of the most accurate subtree, but whose size is smaller, following Quinlan (1986). Although Mingers' surveys cover multiple value information, for clarity we have worked entirely with binary data in what follows.

We constructed many decision trees for knowledge of HIV status using a variety of explanatory data. Recall that HIV status is known 57 percent of the time by alters, so any such tree would have to have an accuracy significantly higher than 57 percent to be judged successful. For example, we sought to explain HIV status (ak22) using only the 26 relation types in McCarty et al. (2001). A 'cascading' tree was found, with branches consistently only on one side. In other words, the tree had at its first node the question: 'is the alter an acquaintance?' If yes, guess that the alter knows HIV status. If no, the question 'is the alter a former school mate?' follows, with a similar pattern of yes and no routes, and a succession of other questions. However, the accuracy of this

tree was only 63 percent, hardly an improvement on our null hypothesis of 57 percent knowledge.

Instead, we use ethnographic evidence presented in Shelley et al. (1995), and above. This shows that the way sensitive information travels to an alter depends on several criteria, including stigma, amount of opportunity for communication, whether the information would be directly observable (for example, a maimed limb), whether the informant is more naturally reticent and limits information traffic, how well the alter is known, and so on. Not all of these items are independent, of course.

In one sense, this is not an integrated approach, with a formal use of qualitative interview rules leading directly to a set of numerical analyses; and indeed, it cannot be since the study was not designed with this end in mind. Rather, we used the rules as *suggestions* for analyses of potential explanatory variables, which inevitably required a degree of subjective decision on our part.

One version of these criteria is shown in the caption to Figure 3. We examined the narrative data and the reasons people gave for telling/not telling HIV status and compiled a list of variables which we thought might be significant in the choice to reveal HIV status. Some of these variables had to do with whether the participant claimed to generally limit their information flow, how supportive the network member was, how important they were to the informant, etc. The tree possessed 100 nodes after pruning. Despite this complexity, only 20 items were involved in the tree (and eight of those being different relation types). The major predictors are whether the alter is perceived as giving positive support, frequency of contact, and whether the informant chose to limit knowledge of his/her condition. However, while positive support is a good indicator, the later occurrences of whether the alter is on the list of people whom the informant talked about "important, confidential matters" (Burt 1984), how well the alter is known, etc., demonstrate that 'depth of knowing' remains hard to measure. Weight of numbers can also be important: 90 percent of those alters named on the "talked with about important, confidential matters" list (Burt 1984), and 72 percent of the "people who are important to you" (Myers 1981), knew the informant's HIV status. Both these ratios are statistically significantly higher than the norm (indeed, the same holds true for all the items of information). However, only 12 percent of alters were on the Burt list, and 20 percent on Myers. Thus neither of these effects is maximally important for explanatory purposes; there are simply not enough alters involved.

We judge this tree a success, since its classification rate was 78 percent, compared with the original 57 percent classification. Shorter (i.e., more pruned) versions of this tree were noticeably less accurate: a 13-node version (removing the top right-hand column and some of the lower part of the figure, but extending the middle section further) had a classification rate of 72 percent, for example. While noticeably simpler, this more pruned tree is not as efficient by the Mingers criteria.

Figure 3. Upper Part of Tree Diagram for Decision Making about Whether Alters Know Informant's HIV Status. The tree has 100 nodes, and "... " indicates a continuation to finer detail. The decision at a leaf (which is usually obvious from context anyway) is indicated by a circle containing either K (know) or DK (don't know). The tree has a classification rate of 88%; simply choosing that the alter knew the informant's HIV status would have a classification rate of 57%. The responses included were: relation type of alter (26 categories, each y/n), does informant limit knowledge of his/her HIV status, does informant have AIDS, how close is alter, how well does informant know alter, informant's sex, alter's sex, informant's race, health status (good or not good), time since HIV (< 5 years or not), is alter a recipient of confidential matters, does alter live in same area, kind of support given by alter, frequency of contact (either at least once per month, or less often than that). Very few of these responses have any predictive power, as the diagram shows.

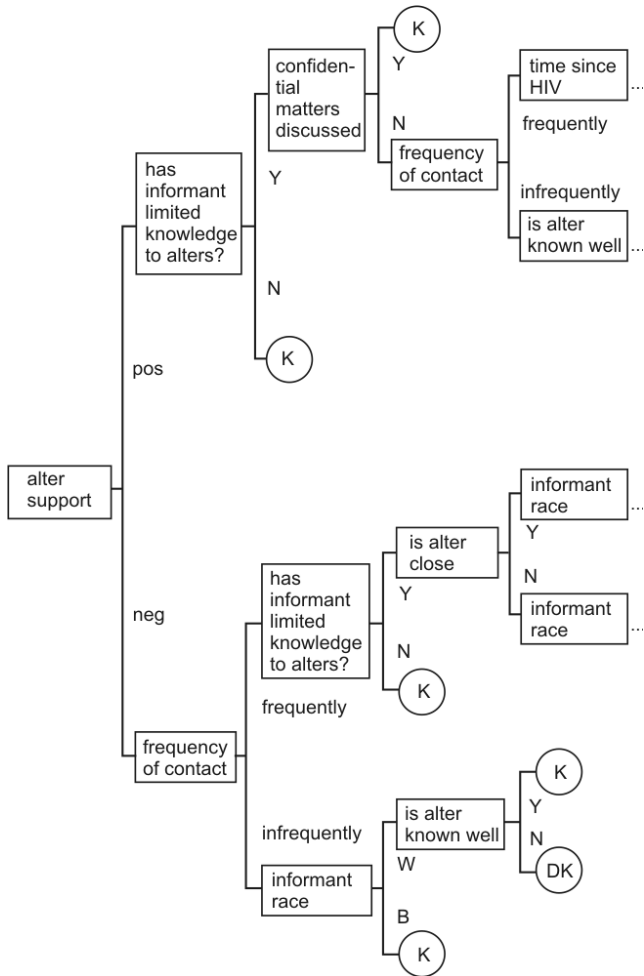

Figure 4. As Figure 3, but Using in Addition Alters' Knowledge of the Informant's Health Status, Driminal Record, Drug History, Important Problems, and Major Events. The pruned tree has 128 nodes and a classification rate of 84%.

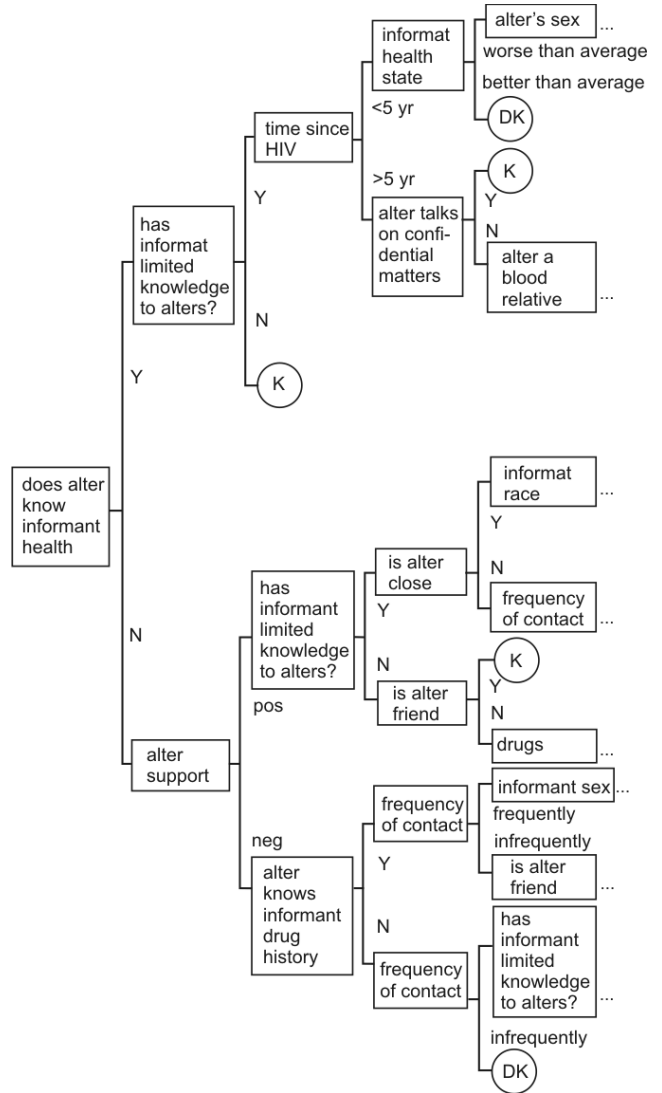

Figure 4 shows a second tree. Here we included the alters' knowledge of the informant's health status, criminal record, drug history, important problems, and major events (ak23, 25, 26, 28 and 29 in note 1) as potential explanatory variables, since we judged these to be highly relevant to the decision whether to tell one's HIV status. The tree was more accurate, with a classification rate of 84 percent. Similar items to the previous tree were found to explain the knowledge of HIV status, with—most obviously—the first decision point based on knowledge of the informant's general health status. It is clear that knowledge of general health status serves as

a good first proxy for knowledge of HIV status, though the correlation between the two items is only 0.52, and we cannot be sure which item was disclosed first by the informant to the alter.

Decision Trees: Predicting Knowledge of HIV Status by Restricted Alter Types

The trees produced above are large and complex. We have simplified the trees by restricting the data used to construct the trees, to that for blood relatives, or friends, or acquaintances. (These selections are all sufficiently large to enable successful tree construction and pruning.) If we continue to restrict attention, additionally, to explaining HIV knowledge, then we can modify the variables included using the earlier ethnographic evidence.

The three trees thus computed consistently included: knowledge of informant's sexual orientation (of relevance only to knowledge about HIV status; 52 percent of informants are gay or bisexual), informant's actual sexual orientation, how well the informant knew the alter, whether the alter provided positive or negative support, if the alter lived in the same area as the informant, the frequency of contact, how close the informant was to the alter, whether the alter was generated by the question "who do you talk with about important, confidential matters", the informant's and alter's races, the time since onset of HIV, the informant's gender, and whether the informant limits knowledge of HIV status.

We consider first the tree explaining whether blood relatives know HIV status (known by 61 percent). In this case, race of informant and alter is irrelevant, of course. The tree, after pruning, had only 13 nodes, and correctly predicts knowledge of HIV status on 81 percent of occasions. Figure 5 shows the entire tree. The decision process initially involves knowledge of informant's sexual orientation (ak27). Regardless of whether the alter knows this, the decision then depends on whether the informant has limited the knowledge of his/her HIV status. Further decisions also depend on temporal values such as frequency of contact and time since HIV onset, and (as we have seen from the previous ethnography) whether the informant's sexual orientation is 'straight' or not.

Figure 6 shows the top of the 54-node decision tree for alters restricted to 'friends'; 62 percent of friends already know HIV status, and the tree improves this to 84 percent correct selection. The decision tree begins with whether the alter offers positive support or not. Further down the tree a structure qualitatively similar to family is seen. We believe that the support variable is a selector mechanism which in fact refines the definition of 'friend' beyond the simple word we supplied to informants.

Finally, Figure 7 shows the complete 13-node tree explaining the decisions for alters who are acquaintances. Only 35 percent of acquaintances know HIV status, so that the null hypothesis of guessing that acquaintances do not know this would be correct 65 percent of the time. The decision model

Figure 5. Complete Tree Diagram for Decision Making about Whether Alters Know Informant's HIV Status, Restricting Attention only to Alters who are Blood Relations of the Informant. The decision at a leaf (which is usually obvious from context anyway) is indicated by a circle containing either K (know) or DK (don't know). The pruned tree has 13 nodes, and a classification rate of 81%. Simply guessing that blood relations know HIV status would have a classification rate of 61%. The explanatory variables used were alter's knowledge of informant's sexual orientation, informant's sexual orientation, how well informant knows alter (coded as yes/no), whether alter provides positive or negative support, if alter lives in the same area as informant, frequency of contact, how close informant is to alter, whether alter is generated by the Burt question "who have you talked to about important matters", informant's race (white or non-white, here irrelevant for blood relations but included for compatibility with the following diagrams), alter's race (ditto), time since onset of HIV, informant's sex, and if informant limits knowledge of HIV status.

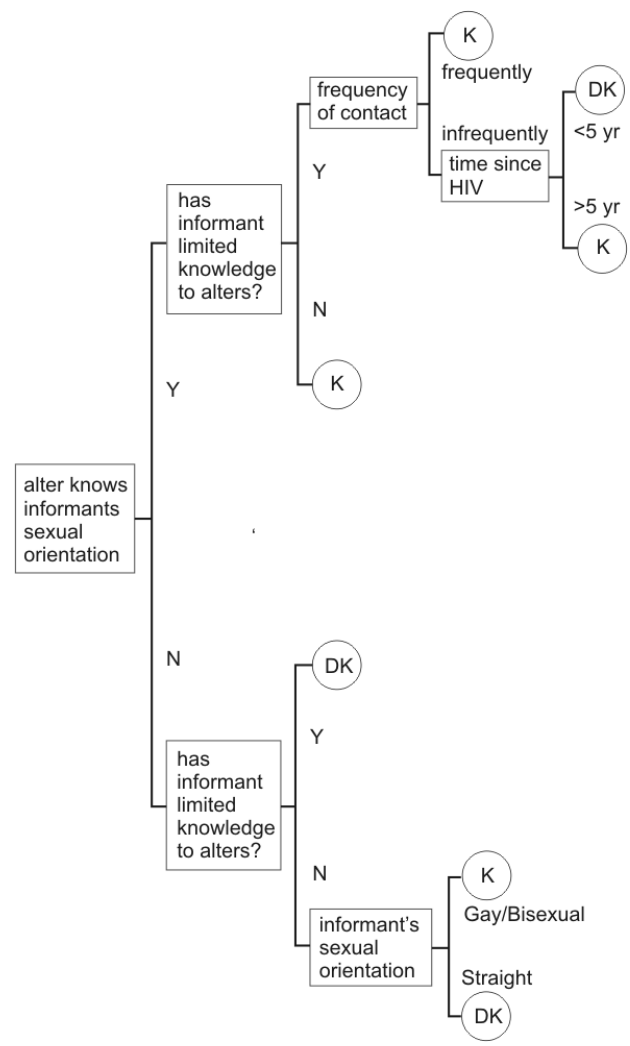
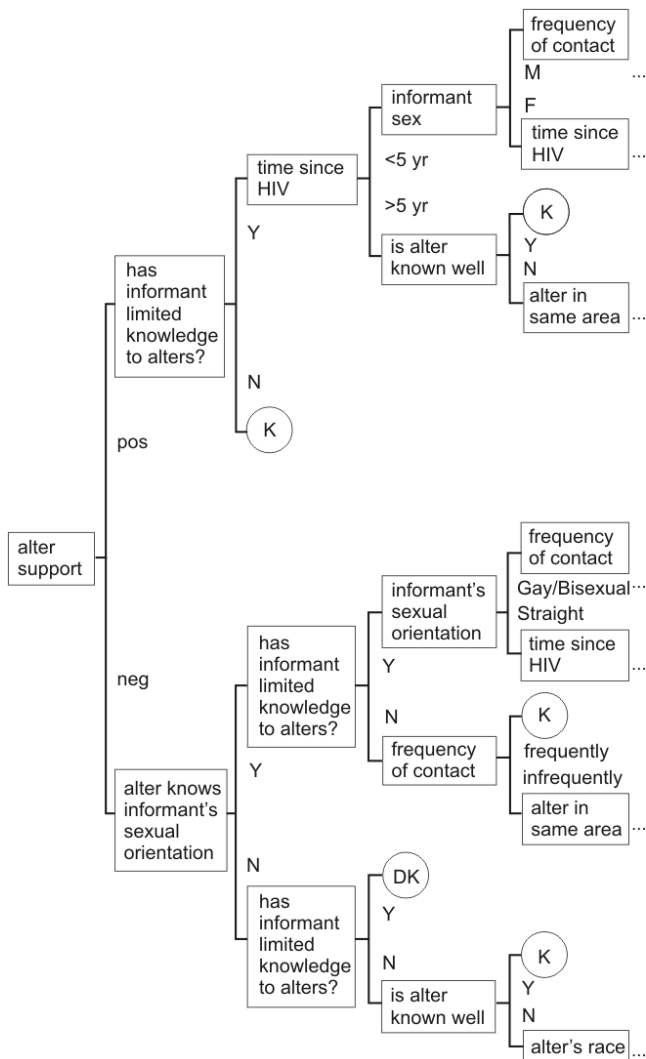
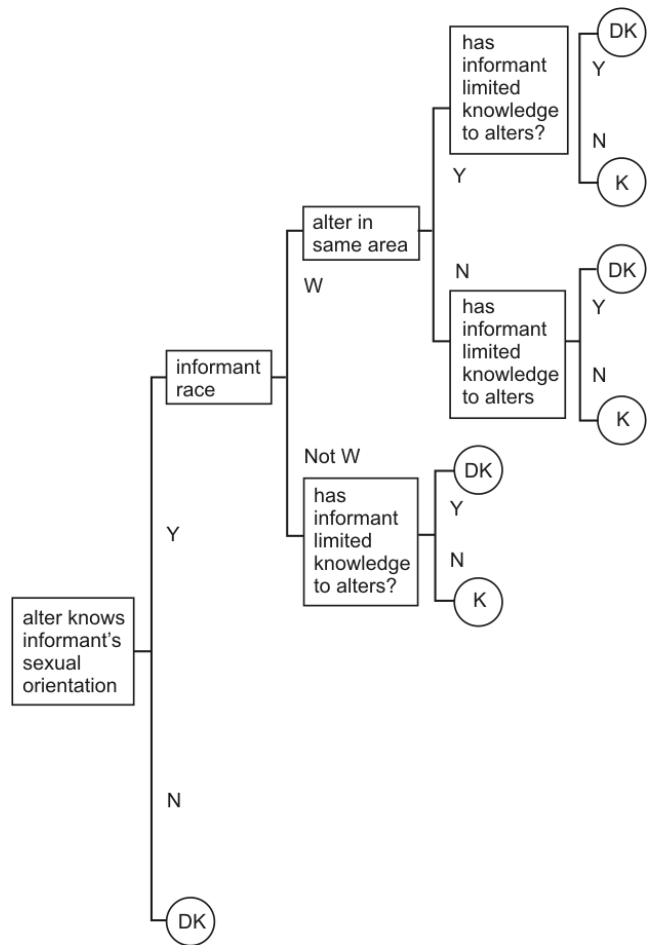

Figure 6. Upper Part of Tree Diagram for Decision Making about Whether Alters Know Informant's HIV Status, Restricting Attention only to Alters who are Friends of the Informant. "..." indicates a continuation to finer detail. The decision at a leaf (which is usually obvious from context anyway) is indicated by a circle containing either K (know) or DK (don't know). The pruned tree has 54 nodes, and a classification rate of 84%. Simply guessing that friends know HIV status would have a classification rate of 62%. Explanatory variables as for Figure 5.



improves this to 79 percent classification. Again knowledge of sexual orientation is the most discriminating variable—so much so that if the alter does *not* know the informant's sexual orientation, the optimal guess is that the alter does not know HIV status either. Otherwise, important variables for the decision include informant's race, whether the alter lives in the

Figure 7. Complete Tree Diagram for Decision Making about Whether Alters Know Informant's HIV Status, Restricting Attention only to Alters who are Acquaintances of the Informant. The decision at a leaf (which is usually obvious from context anyway) is indicated by a circle containing either K (know) or DK (don't know). The pruned tree has 13 nodes, and a classification rate of 79%. Simply guessing that acquaintances do not know HIV status would have a classification rate of 65%. Explanatory variables as for Figure 5; W and NW signifies 'white' and 'non-white' informants.



same area, and again whether knowledge of HIV is limited by the informant. The strong effect of limiting HIV knowledge is seen clearly by the observation that at any node where the criterion is whether knowledge is (or is not) limited, the model immediately predicts that HIV status is not known (or, respectively, is known).

Thus simple decision models for the disclosure of HIV status can be constructed for some classes of alter, particularly blood relatives and acquaintances. Because these limited trees showed this success, we recomputed

Figs. 3 and 4, adding two extra potential discriminatory variables: the informant's sexual orientation, and whether the alter knows the informant's sexual orientation. Only small improvements in classification were made by adding these two items.

Discussion

Data are reported here from people who are HIV-positive concerning what their social network members knew about them. There is wide variation in what informants perceived their alters knew about them, and the characteristics of the relationships affect what people know about each other. Knowing someone well, or closely, or having influence on someone, correlates with knowing a lot about that person. Predictably, in general terms, acquaintances know least, friends know much more and family know the most.

The prediction of a specific individual's knowledge, however, is less simple. For example, people with larger networks do not have a greater chance of their alters knowing information about them than do those with smaller networks. We theorized that opportunity for contact was a factor in information propagation (cf., e.g., Rice and Aydin 1991; Rice 1993). Indeed, people who have known one another for a long time have a greater chance to learn things about one another than do those who have known each other for a shorter time. However, frequency of contact was not especially relevant in the regressions which predict the number of items known. This is probably due to the fact that some family members or old family friends would have been known for the longest times. Some informants were embarrassed to let these long-term relations know they had HIV, because the main modes of transmission are through drugs and sex. One man said, "I have some lady friends I know real well and respect them for a long time. I wouldn't want them to know."

Some things are easy to know and some are not. Many items of information may be known by chance, but other items are closely guarded secrets. It is evident from what informants told us, as well as from much literature, that being HIV-positive can be stigmatizing. This brings us back to our original question: can we explain how HIV-positive people choose whether to tell others about their HIV status? Telling one's HIV status appears to be done mostly on a "need to know basis", e.g. when the informant felt that the alter needed to know in order to protect the alter from contracting HIV, and when the informant felt that a particular alter could provide needed emotional or physical support.

We performed several analyses to answer our question, including correlations, multiple regressions, and discriminant analyses. (We also tried a neural network approach. Unusually for neural network results, the approach yielded less accurate predictions than the decision trees described here.²)

These were generally not helpful in answering the question. Then we attempted to construct a decision tree to answer our question. This proved much more difficult than we imagined, and the process appears to be too complex

to make a simple, small decision tree. It turned out that we needed to segment the data by relationship type, which enabled us to explain the decision rules guiding whether each of family, friends or acquaintances knew about HIV status. Thus decision rules appear to be more powerful when disaggregated by type of primary relationship, as was indicated by some prior research on HIV disclosure (Greene et al. 2003). We suspect that our decision trees should be embeddable in the overall decision schema given by Omarzu (2000), but to achieve this formally would require a dedicated study. In future work on this problem, then, we would collect narratives that address directly the various decision rules that we hypothesize are at work.

These decision trees can be connected back to the role of uncertainty reduction and the risk of conveying information (Berger and Calabrese 1975). For example, whether the alter already knows the (specifically, gay) sexual orientation of the informant touches on the goals of approval of ego, and preserving ego's favorable view of self. An answer of 'yes' would imply that alter is suitable for disclosing one's HIV status to. Here subjective risk is high. Whether the alter limits who knows his or her HIV status touches on the goals of approval, relief and control. An answer of 'yes' means that disclosure would not be an appropriate strategy (other things being equal). Otherwise, limiting knowledge of HIV status keeps subjective risk low.

Our results hint frustratingly at possible underlying structures which we have so far not fully succeeded in elucidating. They raise some interesting questions:

- How does disclosure of information change relationships?
- Can we measure the degree of risk-taking when an informant chooses to tell someone an item of information?
- Is either kind of information accurately known? That is, to what extent are people's perceptions of what they know about their alters and what their alters know about them correct? (In another environment, Rice and Aydin 1991, show that estimated projections about generalized others' attitudes are highly correlated with one's own attitudes, but not strongly correlated with specified others' attitudes; this problem is conceptually articulated by Rice 1993.)
- Does information disclosure tend to be reciprocal, or mainly one-way?

In conclusion: the disaggregated decision tree approach proved the most successful. Even an apparently simple decision—whether or not to tell someone that you are HIV-positive—turns out to be complicated; yet the complexity can be extracted from open-ended interviews.

Notes

¹The 30 items of knowledge about others that were evaluated by informants about their alters (used for both 'ak' and 'ik') were: (1) type of usual work or occupation; (2) work status (working or not); (3) marital status; (4) approximate income; (5) educational level attained; (6) number of siblings; (7) birthplace; (8) current address; (9) number of children; (10) age; (11) real first name; (12) political party; (13) reli-

gious preference; (14) whether or not one is a member of a labor union; (15) whether one has ever been on active duty for military training or service for at least two consecutive months; (16) whether or not one has ever been punched or beaten by another person; (17) whether one has ever been threatened by a gun or shot at; (18) whether during the last year someone broke into or somehow illegally got into one's apartment or home; (19) whether during the last year someone took something directly from one by using force; (20) membership in groups or organizations; (21) amount of time lived in current community and address; (22) HIV status; (23) general health status; (24) blood type; (25) whether or not one has a criminal record; (26) whether or not one has ever been on drugs; (27) sexual orientation; (28) most important problems that one or members of one's household has had during the last 12 months; (29) major events that happened to one during the last 12 months; (30) travel during the past 12 months. Informant data acquired comprised: Race, Gender, Income, Education, Time HIV+, Sexual orientation, Network size (number of alters generated), Whether limited knowledge of HIV status, Categories of others who would be told / not told about HIV status (cf. Table 1). Alter data acquired comprised: Relationship type (e.g. spouse, employee); Gender; Race; Whether alter lives in same area as informant; Time known (1 = less than a month, to 6 = more than five years); Frequency of contact (contacts/day); Closeness (1-5 scale, with 2 being neutral); How well known (on a 1-5 scale); Whether supportive (supportive = +1, neutral = 0, unsupportive = -1); How influential (on a 1-5 scale); Does informant talk to alter about "important, confidential matters"; Is the alter "important to" informant.

²We tried neural network methods as an alternative to the decision tree technique. Using the netlab software from Aston University (Bishop 1995; for details, see <http://www.ncrg.aston.ac.uk/netlab/>) a standard methodology was employed. The order of the data was randomized, and a split-half approach used. A single hidden-layer of variables was fitted from the first half of the data using many different experimental choices of variable groupings (similar to those in the decision trees below). After the neural network was trained on these, it was tested on the second half of the data. Training scores were universally high, between 80 and 90 percent accurate, but the testing half scored values around 65 percent, almost independent of the number of hidden variables (varied between 10 and 30).

References

Backer, T. E. and E. M. Rogers
1998 Diffusion of Innovations Theory and Work-Site AIDS Programs. *Journal of Health Communication* 3:17-28.

Bensing, J.
2000 Bridging the Gap. *The Separate Worlds of Evidence-Based Medicine and Patient-Centered Medicine*. *Patient Education & Counseling* 39:17-25.

Berger, C. R., and R. J. Calabrese
1975 Some Explorations in Initial Interaction and Beyond: Toward a Developmental Theory of Interpersonal Communication. *Human Communication Research* 1:99-112.

Bernard, H. R., P. D. Killworth, and C. McCarty
1982 INDEX: An Informant-Defined Experiment in Social Structure. *Social Forces* 61:99-133.

Bishop, C. M.
1995 *Neural Networks for Pattern Recognition*. New York: Oxford University Press.

Burt, R. S.
1984 Network Items and the General Social Survey. *Social Networks* 6:293-339.

Dearing, J. W., G. Meyer, and E. M. Rogers
1994 Diffusion Theory and HIV Risk Behavior Change. *In Preventing AIDS: Theories and Methods of Behavioral Interventions*. AIDS Prevention and Mental Health. R. J. DiClemente and J. L. Peterson, eds. Pp. 79-93. New York: Plenum Press.

Derlega, V., B. Winstead, K. Greene, J. Serovich, and W. Elwood
2004 Reasons for HIV Disclosure/Nondisclosure in Close Relationships: Testing a Model of HIV-Disclosure Decision Making. *Journal of Social and Clinical Psychology* 23:747-767.

Elford, J., G. Bolding, M. Maguire, and L. Sherr
2000 Do Gay Men Discuss HIV Risk Reduction With Their GP? *AIDS Care* 12:287-290.

Fischer, C.
1982 *To Dwell Among Friends: Personal Networks in Town and City*. Chicago: University of Chicago Press.

Freeman, L. C. and C. R. Thompson
1989 Estimating Acquaintanceship Volume. *In The Small World*. M. Kochen, ed. Pp. 147-158. Norwood: Ablex.

Fullilove, M. and R. E. Fullilove, III
1999 Stigma as an Obstacle to AIDS Action. *American Behavioral Scientist* 42:1117-1129.

Gatewood, J. B.
1983 Deciding Where to Fish: The Skipper's Dilemma in Southeast Alaska's Salmon Seining. *Coastal Zone Management Journal* 10:347-367.

Gladwin, H.
1971 Decision Making in the Cape Coast (Fante) Fishing and Fish Marketing System. Ph.D. dissertation, Stanford University.

Gladwin, C. H.
1976 A View of Plan Puebla: An Application of Hierarchical Decision Models. *Journal of Agricultural Economics* 59:881-887.
1980 A Theory of Real Life Choice: Applications to Agricultural Decisions. *In Agricultural Decision Making*. P. Barlett, ed. New York: Academic Press.
1989 *Ethnographic Decision Tree Modeling*. Beverly Hills, Calif.: Sage.

Greene, K.
2000 Disclosure of Chronic Illness Varies by Topic and Target: The Role of Stigma and Boundaries in Willingness to Disclose. *In Balancing the Secrets of Private Disclosures*. S. Petronio, ed. Pp. 123-135. Mahwah, N.J.: Lawrence Erlbaum Associates, Inc.

Greene, K. and S. Faulkner
2002 Expected Versus Actual Responses to Disclosure in Relationships of HIV-Positive African American Adolescent Females. *Communication Studies* 53:297-317.

Greene, K., V. J. Derlega, G. A. Yep, and S. Petronio
2003 *Privacy and Disclosure of HIV in Interpersonal Relationships: A Sourcebook for Researchers and Practitioners*. Mahwah, N.J.: Lawrence Erlbaum Associates, Inc.

Herd, G.
2001 Stigma and the Ethnographic Study of HIV: Problems and Prospects. *AIDS and Behavior* 5:141-149.

- Hill, C. E.
1998 Decision Modeling: Its Use in Medical Anthropology. *In* Using Methods in the Field. V.C. de Munck and E. J. Sobo, eds. Pp. 139-164. Walnut Creek, Calif.: AltaMira Press.
- Johnsen, E. C., H. R. Bernard, P. D. Killworth, G. A. Shelley, and C. McCarty
1995 A Social Network Approach to Corroborating the Number of AIDS/HIV+ Victims in the US Social Networks 17:167-87.
- Killworth, P. D., E. C. Johnsen, H. R. Bernard, G. A. Shelley, and C. McCarty
1990 Estimating the Size of Personal Networks. *Social Networks* 12:289-312.
1998 Estimation of Seroprevalence, Rape and Homelessness in the U.S. Using a Social Network Approach. *Evaluation Review* 22:289-308.
- Latkin, C. A., A. R. Knowlton, V. L. Forman, D. R. Hoover, J. R. Schroeder, M. Hachey, and D. D. Celentano
2001 Injection Drug Users' Disclosure of HIV Seropositive Status to Network Members. *AIDS and Behavior* 5:297-305.
- Lee, R. S., A. Kochman, and K. J. Sikkema
2002 Internalized Stigma Among People Living with HIV-AIDS. *AIDS and Behavior* 6:309-319.
- McCarty, C., P. D. Killworth, H. R. Bernard, E. C. Johnsen, and G. A. Shelley
2001 Comparing Two Methods for Estimating Network Size. *Human Organization* 60:28-39.
- McLean, R.
2003 Deconstructing Black Gay Shame: A Multicultural Perspective on the Quest for a Healthy Ethnic and Sexual Identity. *In* Multicultural Competencies: A Guidebook of Practices. G. Roysircar, ed. Pp. 109-118. Alexandria, Va.: Association for Multicultural Counseling and Development.
- Mathews, H. F. and C. Hill
1990 Applying Cognitive Decision Theory to the Study of Regional Patterns of Illness Treatment Choice. *American Anthropologist* 91:55-170.
- Mays, V. M., Cochran, S. D., and M. R. Roeder
2003 Depressive Distress and Prevalence of Common Problems Among Homosexually Active African American Women in the United States. *Journal of Psychology and Human Sexuality* 15:27-46.
- Mingers, J.
1989 An Empirical Comparison of Selection Measures for Decision-Tree Induction. *Machine Learning* 3:319-342.
1990 An Empirical Comparison of Pruning Methods for Decision-Tree Induction. *Machine Learning* 4:227-243.
- Myers, H.
1981 Resources and Social Support Measure. Department of Psychology, University of California, Los Angeles, and Department of Psychiatry and Human Behavior, Charles R. Drew Medical School, Los Angeles.
- Omarzu, J.
2000 A Disclosure Decision Model: Determining How and When Individuals Will Self-Disclose. *Personality and Social Psychology Review* 2:174-185.
- Parker, R. and A. A. E. Ehrhardt
2001 Through an Ethnographic Lens: Ethnographic Methods, Comparative Analysis, and HIV/AIDS Research. *AIDS and Behavior* 5:105-114.
- Pequegnat, W., L. Bauman, J. H. Bray, R. DiClemente, C. DiIorio, S. K. Hoppe, L. S. Jemmott, B. Krauss, M. Miles, R. Paikoff, B. Rapkin, M. J. Rotheram-Borus, and J. Szapocznik
2001 Measurement of the Role of Families in Prevention and Adaptation to HIV/Aids. *AIDS and Behavior* 5:1-19.
- Plattner, S.
1982 Economic Decision Making in a Public Marketplace. *American Ethnologist* 9:399-420.
- Quinlan, J. R.
1986 Induction of Decision Trees. *Machine Learning* 1:81-106.
- Quinn, N.
1978 Do Mfantse Fish Sellers Estimate Probabilities in Their Heads? *American Ethnologist* 5:206-226.
- Rice, R. E.
1993 Using Network Concepts to Clarify Sources and Mechanisms of Social Influence. *In* Progress in Communication Sciences: Advances in Communication Network Analysis. W. Richards, Jr. and G. Barnett, eds. Pp. 43-52. Norwood N.J.: Ablex.
- Rice, R. E. and C. Atkin, eds.
2001 Public Communication Campaigns. 3rd ed. Thousand Oaks, Calif.: Sage.
- Rice, R. E. and C. Aydin
1991 Attitudes Towards New Organizational Technology: Network Proximity as a Mechanism for Social Information Processing. *Administrative Science Quarterly* 36:219-244.
- Rogers, E. M.
1996 The Field of Health Communication Today: An Up-to-Date Report. *Journal of Health Communication* 1:15-23.
2000 Diffusion Theory: A Theoretical Approach to Promote Community-Level Change. *In* Handbook of HIV Prevention. AIDS Prevention and Mental Health. J. L. Peterson and R. J. DiClemente, eds. Pp. 57-65. New York: Kluwer Academic/Plenum.
- Ryan, G. W. and H. R. Bernard
2006 Testing an Ethnographic Decision Tree Model on a National Sample: Recycling Beverage Cans. *Human Organization* 65:103-115.
- Ryan, G. W. and H. Martinez
1996 Can We Predict What Mothers Do? Modeling Childhood Diarrhea in Rural Mexico. *Human Organization* 55:47-57.
- Serovich, J., J. Kimberly, and K. Greene
1998 Perceived Family Member Reaction to Women's Disclosure of HIV-Positive Information. *Family Relations* 47:15-22.
- Shelley, G. A., H. R. Bernard, and P. D. Killworth
1990 Information Flow in Social Networks. *Journal of Quantitative Anthropology* 2:201-225.
- Shelley, G. A., H. R. Bernard, P. D. Killworth, E. C. Johnsen, and C. McCarty
1995 Who Knows Your HIV Status? What HIV+ Patients and Their Network Members Know About Each Other. *Social Networks* 17:189-217.

Sherman, B. F., G. A. Bonanno, L. S. Wiener, and H. B. Battles
2000 When Children Tell Their Friends They Have AIDS: Possible
Consequences for Psychological Well-Being and Disease
Progression. *Psychosomatic Medicine* 62:238-247.

Simoni, J. M., P. Demas, H. R. C. Mason, J. A. Drossman, and M. L.
Davis
2000 HIV Disclosure among Women of African Descent:
Associations with Coping, Social Support, and Psychological
Adaptation. *AIDS and Behavior* 4:147-158.

Weller, S. C., T. K. Ruebush II, and R. E. Klein
1997 Predicting Treatment-Seeking Behavior in Guatemala: A
Comparison of the Health Services Research and Decision-Theoretic
Approaches. *Medical Anthropology Quarterly* 11:224-245.

Young, J. C.
1980 A Model of Illness Treatment Decisions in a Tarascan Town.
American Ethnologist 7:106-151.

Young, J. C. and L. C. Garro
1994 *Medical Choice in a Mexican Village*. New Brunswick, N.J.:
Rutgers University Press.